

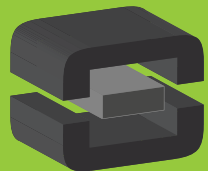

From Off-The-Shelf to Market-Ready© New Age Enclosures is your Single Source Solution.  
Let us quote modifying our Stock Enclosures to meet your end-use.  
visit [newageenclosures.com/services](http://newageenclosures.com/services) or call 855-4NA-ENCL today.

**CNC CUTOUTS**  
**PART DECORATING**  
**CUSTOM COLOR AND MATERIAL**  
**RF/EMI SHEILDING**  
**CUSTOM TOOL INSERTS**  
**CUSTOM ENCLOSURES AND DESIGN**



**NEW AGE**  
**ENCLOSURES**

DEVELOP THE FUTURE



NOTES: UNLESS OTHERWISE SPECIFIED

1. CORNERS DRAWN SHARP TO BE R.005 MAXIMUM.
2. EXTERIOR SURFACE TEXTURE TO BE LIGHT EDM FINISH. EQUIVALENT TO MT-11010.
3. INTERIOR SURFACE TEXTURE TO BE: NONE.
4. ALL INSIDE RADII .010R. UNLESS OTHERWISE SPECIFIED.
5. ALL EXTERNAL DIMENSIONS AFFECTED BY THE DRAFT APPLY AT THE LARGE END OF THE FEATURE, AND ALL INTERNAL FEATURES AFFECTED BY THE DRAFT APPLY AT THE SMALL END OF THE FEATURE UNLESS OTHERWISE SPECIFIED.
6. 1 DEGREE DRAFT IN THE DIRECTION OF PULL IS PERMISSIBLE UNLESS OTHERWISE SPECIFIED.
7. MATERIAL / COLOR: ABS PLASTIC IS STANDARD IN BLACK OR WHITE. CUSTOM MATERIALS AND COLORS ARE AVAILABLE UPON REQUEST FOR QUOTE. ALTERNATE RESINS HAVE DIFFERENT SHRINK RATES, AND WILL EFFECT DIMENSIONS.
8. PCB SIZES ARE RECOMMENDATIONS ONLY. FINAL SIZES AND VERIFICATION OF ITS FIT ARE THE SOLE RESPONSIBILITY OF EACH CUSTOMER.
9. ASSEMBLY SCREWS FOR THE ENCLOSURE INCLUDED.
10. THIS DRAWING IS BASED ON A SOLID MODEL, AND IS FURTHER DEFINED BY THE SOLID MODEL FILE.
11. ALLOWABLE FLASH: 0.015 MAX.
12. ALL EJECTOR PIN MARKS TO BE WITHIN 0.015" OF FLUSH, PROTRUDING OR BELOW FLUSH.
13. TRIM GATE WITHIN 0.030" OF FLUSH.

R E V I S I O N					
REV.	DRAWN BY	ECO No	DESCRIPTION	DATE	APPROVE
A	M BOYER	JUSTIN	PRELIMINARY RELEASE	2019-Jan-21	D.C.
B	M BOYER		REVISE TEXTURE	2019-Jan-29	D.C.
C	M BOYER		REVISE PER DESIGN FEEDBACK	2019-Feb-26	D.C.
1.0	M BOYER		UPDATE MODEL TO AS-BUILT AND RELEASE	2019-Aug-08	

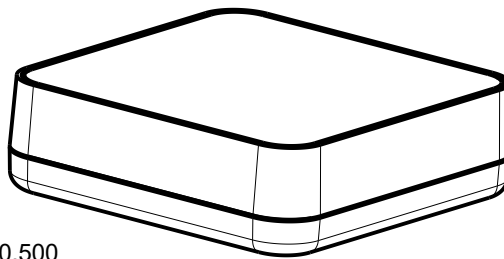
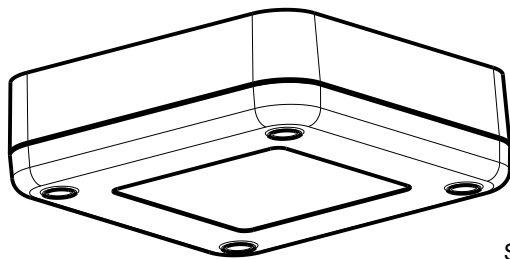
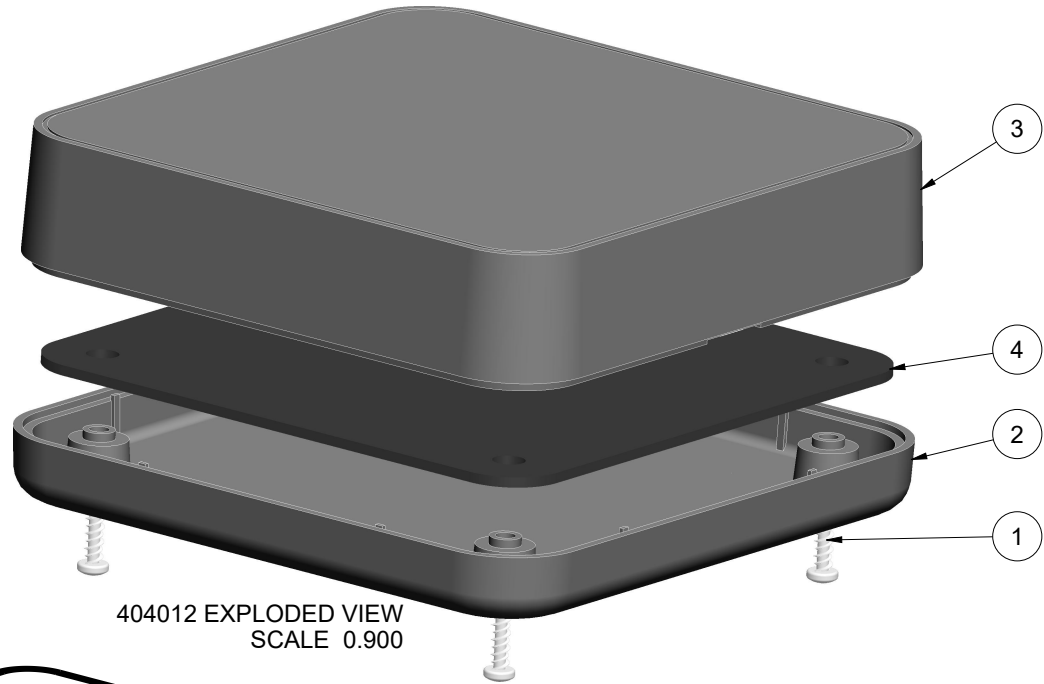

SCALE 0.500

ITEM	FILE NAME	DESCRIPTION	MATERIAL	COLOR	QTY.
4	404012-PCB_062	404012 PCB - REFERENCE	.062" THICK	CUSTOMER SUPPLIED	1
3	404012-COVER	404012 COVER - STANDARD	ABS	BLACK or WHITE	1
2	404012-BASE	404012 BASE - STANDARD	ABS	BLACK or WHITE	1
1	SCREW_HILO-N04X375	#4 HILO x .375" SCREW	ZINK PLATED	3/8" LONG	4

BILL OF MATERIALS

THIRD ANGLE PROJECTION 		TOLERANCES: UNLESS OTHERWISE SPECIFIED DIMENSIONS ARE IN U.S. INCHES. X.XX = .015 X.XXXX = .001 X.XXX = .010 X.X" = 1°		<b>NEW AGE ENCLOSURES</b>	
DO NOT SCALE DRAWING		Customer's Part No: 404012		2240 South Thornburg Street Santa Maria, CA. 93455 ph. (805) 595-1310 fax (805) 595-1024 www.newageenclosures.com	
APPROVAL	BY	DATE	SENSOR CUBE - STANDARD SXX-404012-XXX		
CHECK					
ENG.					
SCALE	AS NOTED				
DRAWN BY	2019-Jan-21	SIZE	DRAWING NAME	SHEET	REV.DOC
M BOYER		A	404012_CUBE_R1_0	1 OF 6	1.0

# 404012 ASSEMBLY

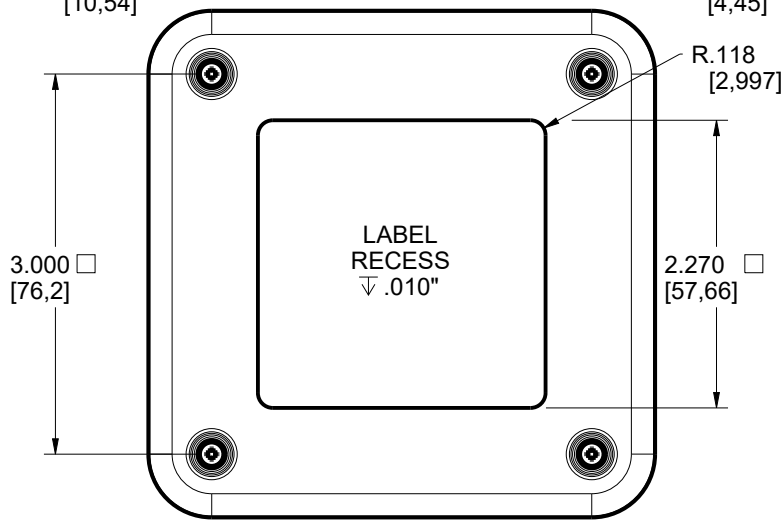
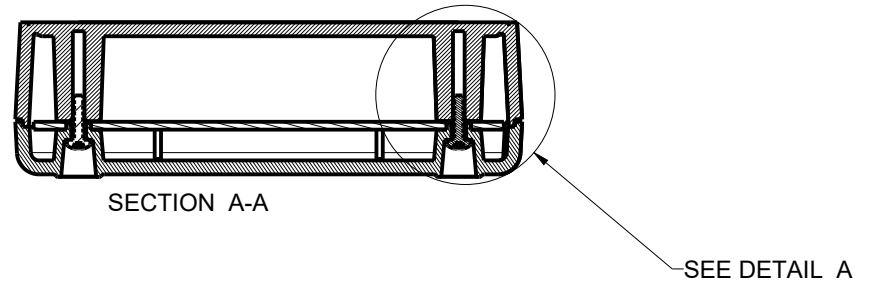
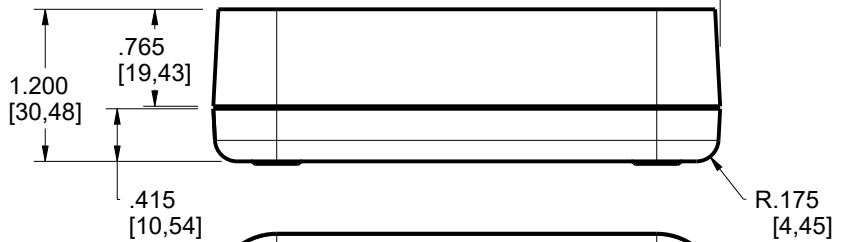
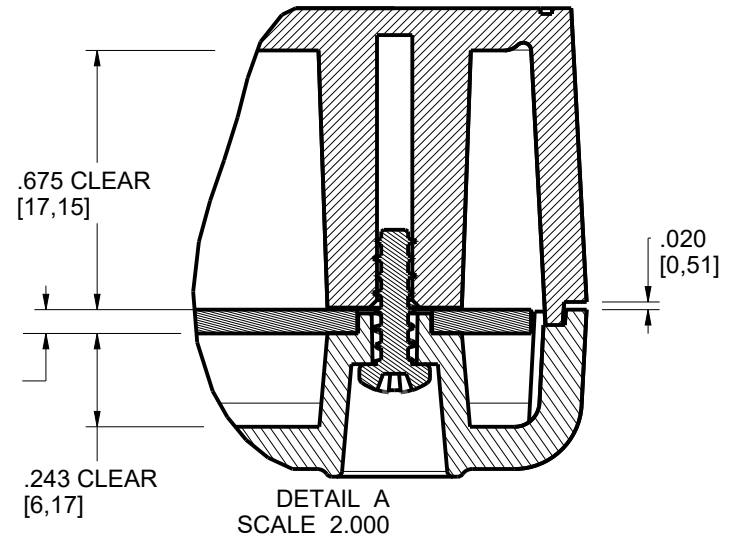
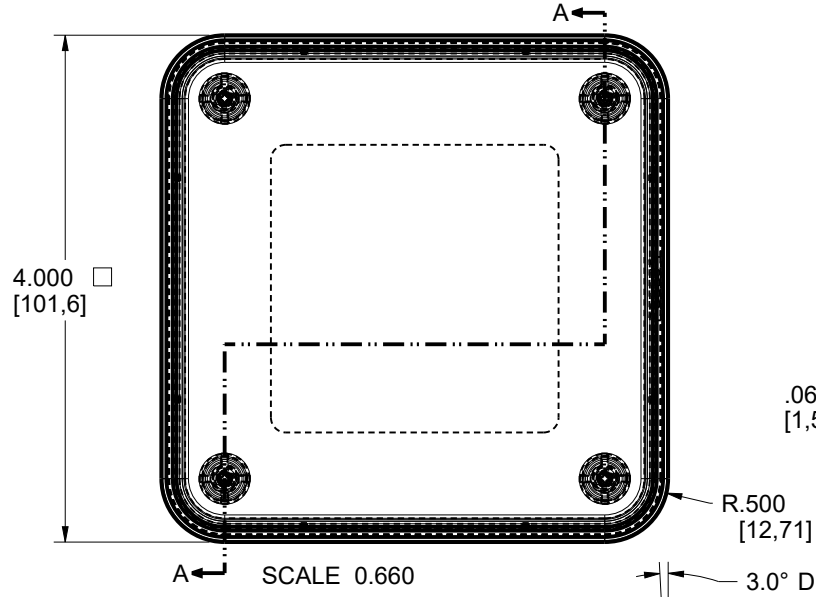

TOLERANCES: UNLESS OTHERWISE SPECIFIED DIMENSIONS ARE IN U.S. INCHES. X.XX = .015 X.XXXX = .001 X.XXX = .010 X.X° = 1°		<b>NEW AGE ENCLOSURES</b>	
NEW AGE ENCLOSURES		2240 South Thornburg Street Santa Maria, CA. 93455 ph. (805) 595-1310 fax (805) 595-1024 www.newageenclosures.com	
Customer's Part No: 404012			
APPROVAL	BY	DATE	SENSOR CUBE - STANDARD SXX-404012-XXX
CHECK			
ENG.			
SCALE	AS NOTED		
DRAWN BY		SIZE	DRAWING NAME
M BOYER	2019-Jan-21	A	404012_CUBE_R1_0
SHEET	REV.DOC		
2 OF 6	1.0		

# 404012 COVER

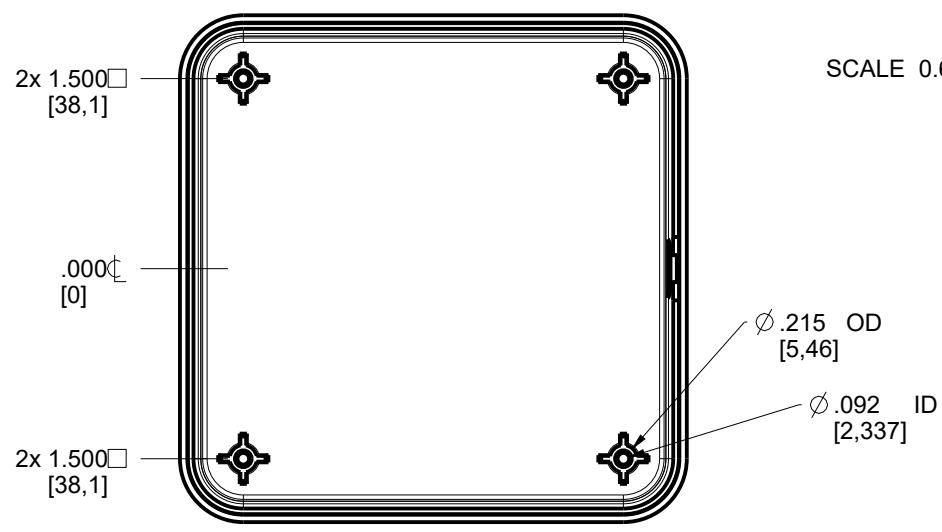
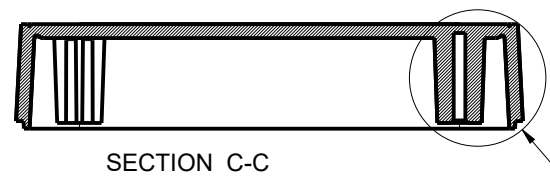
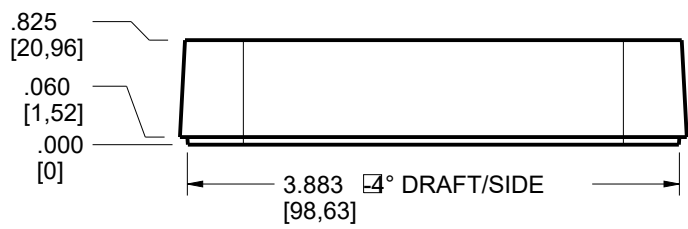
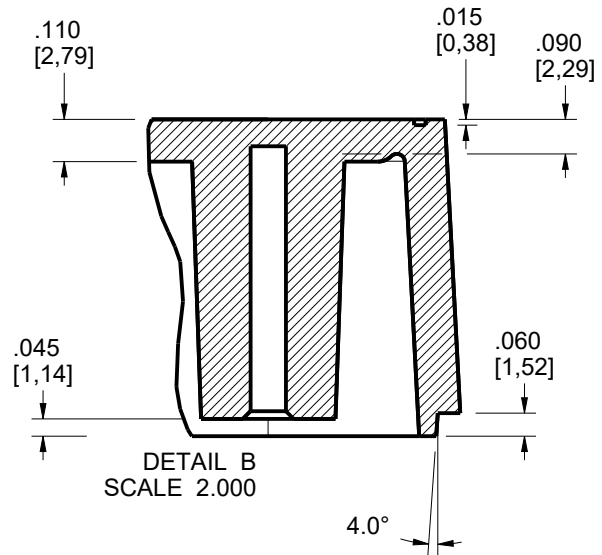
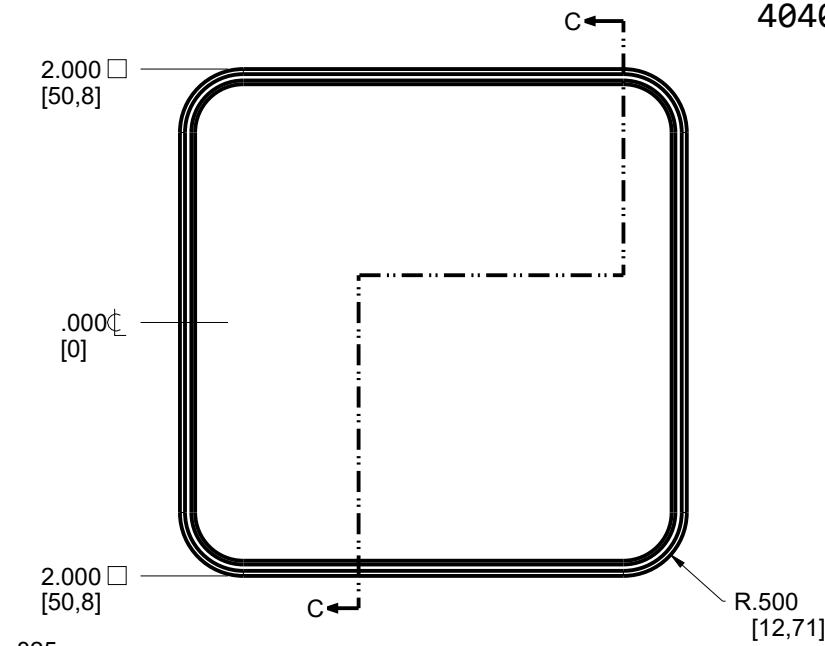

SCALE 0.660

SEE DETAIL B

TOLERANCES: UNLESS OTHERWISE SPECIFIED DIMENSIONS ARE IN U.S. INCHES. X.XX = .015 X.XXXX = .001 X.XXX = .010 X.X° = 1°		<b>NEW AGE ENCLOSURES</b>	
Customer's Part No: 404012		2240 South Thornburg Street Santa Maria, CA. 93455 ph. (805) 595-1310 fax (805) 595-1024 www.newageenclosures.com	
APPROVAL	BY	DATE	SENSOR CUBE - STANDARD SXX-404012-XXX
CHECK			
ENG.			
SCALE	AS NOTED		
DRAWN BY	SIZE	DRAWING NAME	SHEET
M BOYER	A	404012_CUBE_R1_0	3 OF 6
	2019-Jan-21		REV.DOC
			1.0

# 404012 BASE

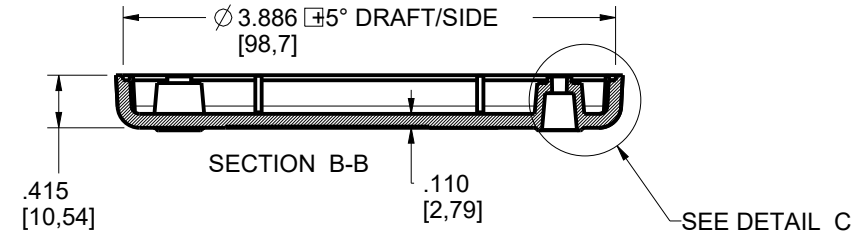
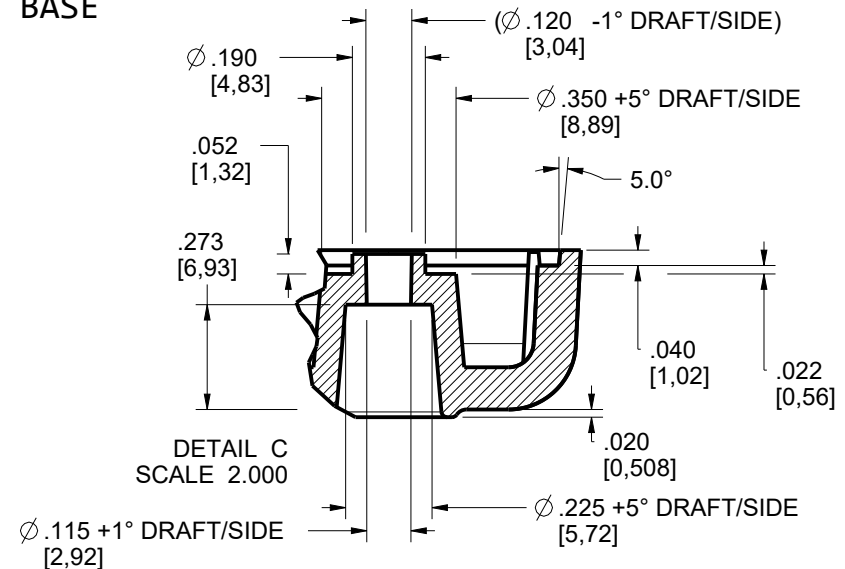
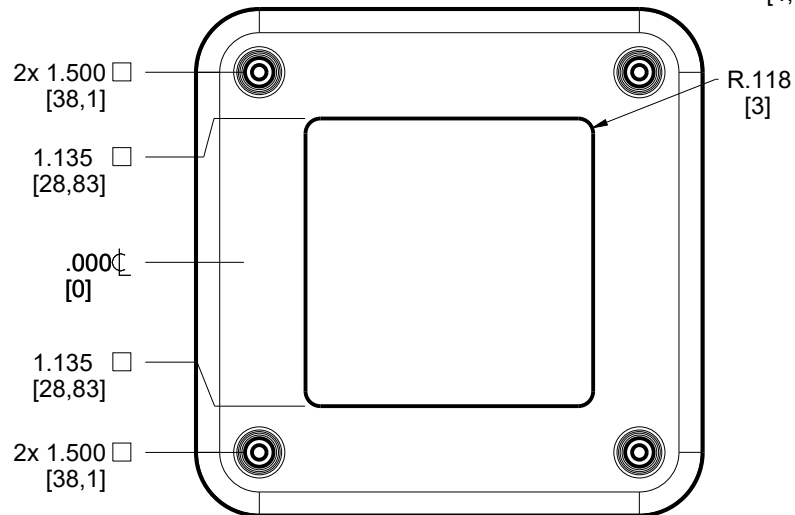
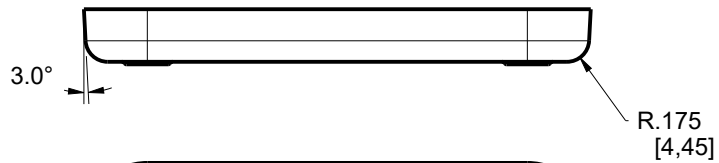
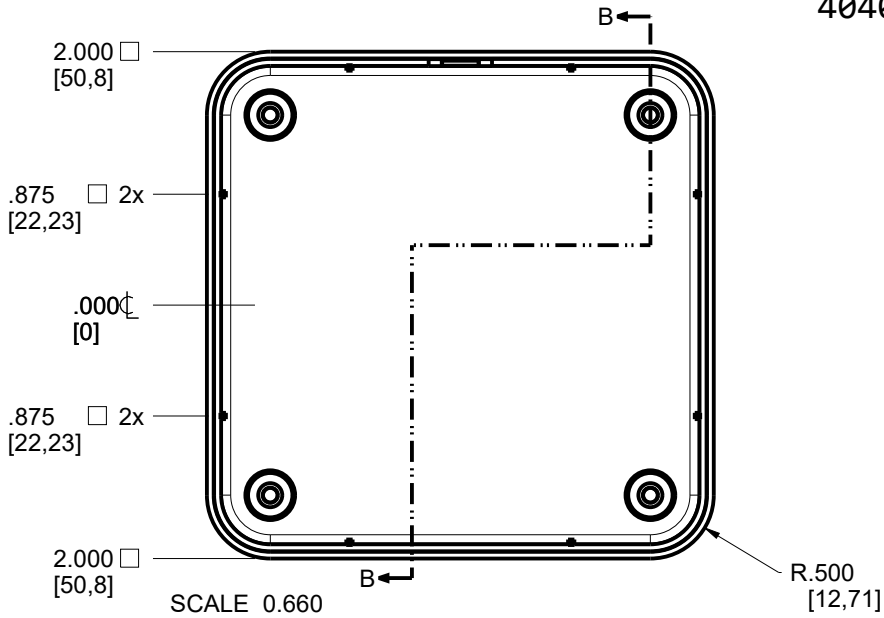

TOLERANCES: UNLESS OTHERWISE SPECIFIED  
DIMENSIONS ARE IN U.S. INCHES.  
X.XX = .015 X.XXXX = .001  
X.XXX = .010 X.X° = 1°

NEW AGE ENCLOSURES  
Customer's Part No: 404012

APPROVAL	BY	DATE
CHECK		
ENG.		
SCALE	AS NOTED	
DRAWN BY	M BOYER	
	2019-Jan-21	

**NEW AGE ENCLOSURES**  
2240 South Thornburg Street Santa Maria, CA. 93455  
ph. (805) 595-1310 fax (805) 595-1024  
www.newageenclosures.com

**SENSOR CUBE - STANDARD**  
SXX-404012-XXX

SIZE	DRAWING NAME	SHEET	REV.DOC
A	404012_CUBE_R1_0	4 OF 6	1.0

404012 PCB .062" - CUSTOMER SUPPLIED

PCB SIZES ARE RECOMMENDATIONS ONLY. FINAL SIZES AND VERIFICATION OF ITS FIT ARE THE SOLE RESPONSIBILITY OF THE OEM.

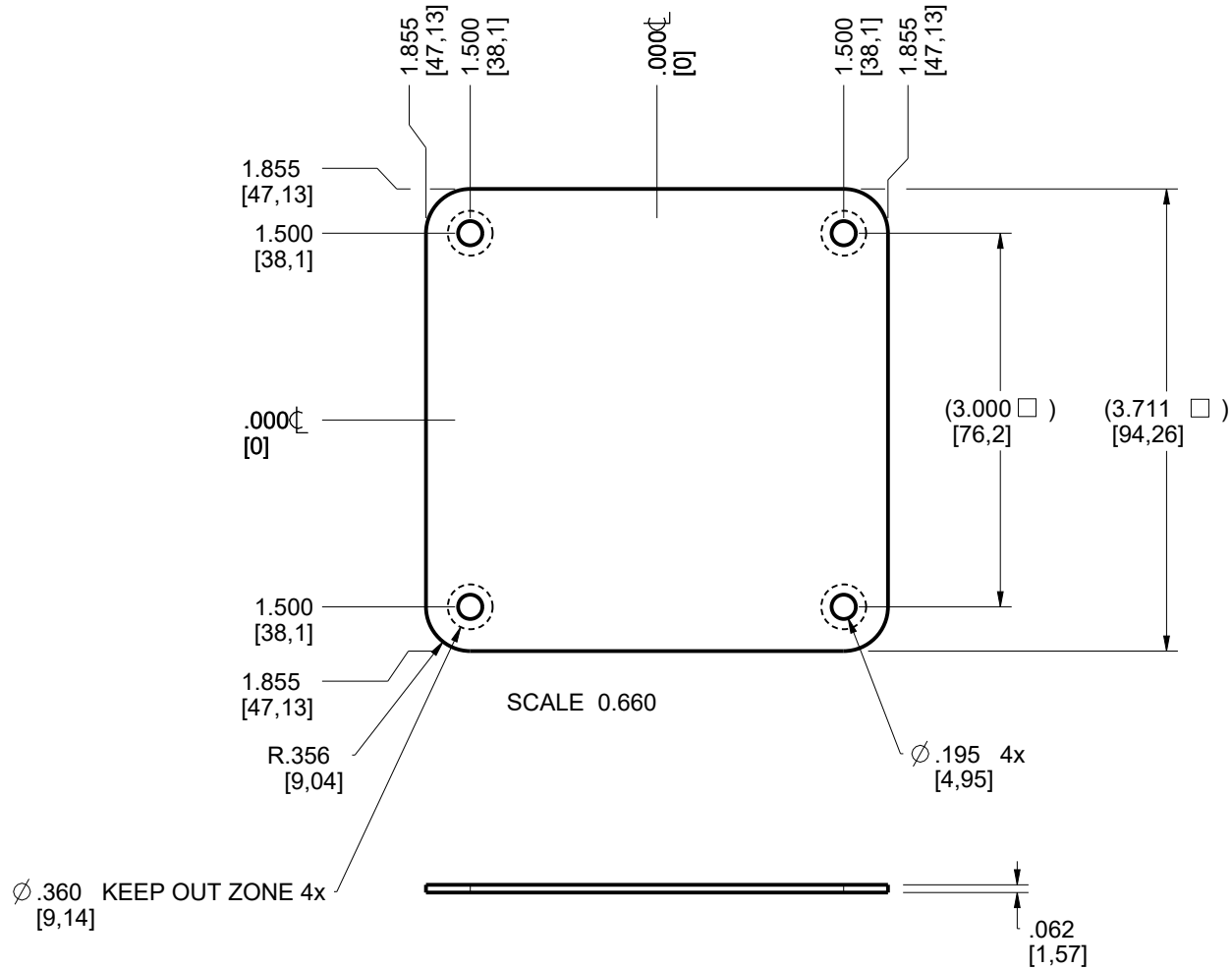

TOLERANCES: UNLESS OTHERWISE SPECIFIED  
DIMENSIONS ARE IN U.S. INCHES.  
X.XX = .015 X.XXXX = .001  
X.XXX = .010 X.X° = 1°

NEW AGE ENCLOSURES  
Customer's Part No: 404012

APPROVAL	BY	DATE
CHECK		
ENG.		
SCALE	AS NOTED	

DRAWN BY	2019-Jan-21
M BOYER	

**NEW AGE ENCLOSURES**  
2240 South Thornburg Street Santa Maria, CA. 93455  
ph. (805) 595-1310 fax (805) 595-1024  
www.newageenclosures.com

SENSOR CUBE - STANDARD  
SXX-404012-XXX

SIZE	DRAWING NAME	SHEET	REV.DOC
A	404012_CUBE_R1_0	5 OF 6	1.0

## 404012 - 2nd OPERATION DETAILS

NEW AGE ENCLOSURES DELIVERS YOUR ENCLOSURE MARKET-READY WITH IN-HOUSE  
CNC MACHINING, PAD PRINTING, ASSEMBLY, AND FULFILLMENT.  
ALL SURFACES AND AREAS ARE AVAILABLE FOR CNC ALTERATION BY NEW AGE ENCLOSURES  
CALL (805) 595-1310 FOR PRICING AND SCHEDULE.  
THE INSIDE RADIUS OF ANY MACHINED FEATURES SHOULD BE NO SMALLER THAN .031"

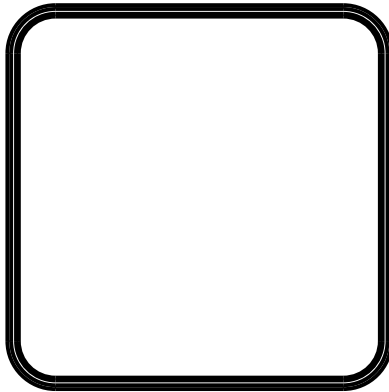

404012 COVER  
SCALE 0.500

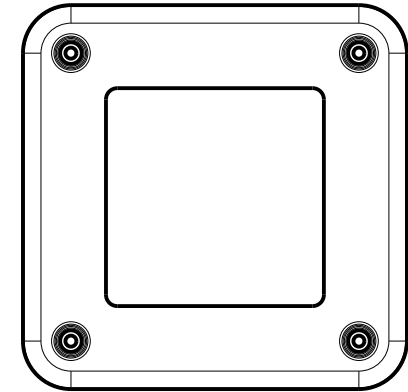

404012 BASE  
SCALE 0.500



SXX-404012-XXX COVER - ABS, BLACK					
STEP NO	DESCRIPTION	CUTTER	FIXTURE	ORIENTATION	PROGRAM
1-C-C1	-	T2 = .062" EM	-		o3201
2-C-C2	-	T2 = .062" EM	-		o3202

SXX-404012-XXX COVER - ABS, BLACK				
STEP NO	DESCRIPTION	INK COLOR	CLICHE DESCRIPTION	CLICHE No.
3-C-P1	PAD PRINT			CLXXXX R1

TOLERANCES: UNLESS OTHERWISE SPECIFIED  
DIMENSIONS ARE IN U.S. INCHES.  
X.XX = .015 X.XXXX = .001  
X.XXX = .010 XX° = 1°

**NEW AGE ENCLOSURES**  
Customer's Part No: 404012

APPROVAL	BY	DATE
CHECK		
ENG.		
SCALE	AS NOTED	
DRAWN BY	2019-Jan-21	
M BOYER		

**NEW AGE ENCLOSURES**  
2240 South Thornburg Street Santa Maria, CA. 93455  
ph. (805) 595-1310 fax (805) 595-1024  
[www.newageenclosures.com](http://www.newageenclosures.com)

**SENSOR CUBE - STANDARD**  
**SXX-404012-XXX**

SIZE	DRAWING NAME	SHEET	REV.DOC
A	404012_CUBE_R1_0	6 OF 6	1.0